

TECHNICAL MANUAL

OPERATOR, ORGANIZATIONAL, DIRECT SUPPORT,
AND GENERAL SUPPORT MAINTENANCE MANUAL
INCLUDING REPAIR PARTS AND SPECIAL TOOLS LISTS

POWER SUPPLY PP-2309B/U

This copy is a reprint which includes current
pages from Change 1.

WARNING

High voltages and currents exist in this equipment. Serious injury or death may result from contact with the output terminals.

DON'T TAKE CHANCES!

CHANGE }
 No. 1 }

HEADQUARTERS
 DEPARTMENT OF THE ARMY
 WASHINGTON, DC, 10 August 1981

**Operator, Organizational, Direct Support,
 and General Support Maintenance Manual
 POWER SUPPLY PP-2309B/U
 (NSN 6130-00-752-2215)**

TM 11-6130-245-14-1, 22 March 1972, is changed as follows:

1. The title of the manual is changed as shown above.
2. A vertical bar appears opposite changed material.
3. Remove old pages and insert new pages as indicated in the page list below:

<i>Remove</i>	<i>Insert</i>
<i>None</i>	A and B (front of manual)
1-1 and 1-2	1-1 and 1-2
2-1 and 2-2	2-1 and 2-2
3-1 and 3-2	3-1 and 3-2
7-5 and 7-6	7-5 and 7-6
C-1 through C16	None

4. File this change sheet in front of the manual for reference purposes.

By Order of the Secretary of the Army:

Official:

ROBERT M. JOYCE
Brigadier General, United States Army
The Adjutant General

E. C. MEYER
General, United States Army
Chief of Staff

Distribution:

To be distributed in accordance with special mailing list.

WARNING

Power Supply PP-2309B/U weighs 105 pounds. Be *careful* when moving. Two people are required for four foot or *lower* lift. A mechanical carry is needed to move the power supply more than five steps.

Adequate ventilation should be provided while using TRI-CHLOROTRIFLUOROETHANE. Prolonged breathing of vapor should be avoided. The solvent should not be used near heat or open flame; the products of decomposition are toxic and irritating. Since TRI-CHLOROTRIFLUOROETHANE dissolves natural oils, prolonged contact with skin should be avoided. When necessary, use gloves which the solvent cannot penetrate. If the solvent is taken internally, consult a physician immediately.



5

SAFETY STEPS TO FOLLOW IF SOMEONE IS THE VICTIM OF ELECTRICAL SHOCK

1

DO NOT TRY TO PULL OR GRAB THE INDIVIDUAL

2

IF POSSIBLE , TURN OFF THE ELECTRICAL POWER

3

IF YOU CANNOT TURN OFF THE ELECTRICAL POWER, PULL, PUSH, OR LIFT THE PERSON TO SAFETY USING A WOODEN POLE OR A ROPE OR SOME OTHER INSULATING MATERIAL

4

SEND FOR HELP AS SOON AS POSSIBLE

5

AFTER THE INJURED PERSON IS FREE OF CONTACT WITH THE SOURCE OF ELECTRICAL SHOCK, MOVE THE PERSON A SHORT DISTANCE AWAY AND IMMEDIATELY START ARTIFICIAL RESUSCITATION



Operator, Organizational, Direct Support, and General Support Maintenance Manual
Including Repair Parts and Special Tools Lists

POWER SUPPLY PP-2309B/U

	Paragraph	Page
CHAPTER 1. INTRODUCTION		
Section I. General		
Scope	1-1	1-1
Indexes of publications	1-2	1-1
Forms and records	1-3	1-1
Section II. Description and data		
Purpose and use	1-4	1-2
Technical characteristics	1-5	1-2
Components	1-6	1-2
Description of equipment	1-7	1-2
CHAPTER 2. OPERATION		
Section I. Service upon receipt of equipment		
Unpacking	2-1	2-1
Checking unpacked equipment	2-2	2-1
Section II. Controls, indicators, and operating instructions		
Operating controls and indicators	2-3	2-2
Rear panel terminal strip TS3 connections (local and remote sense)	2-4	2-3
Operating procedure	2-5	2-4
Stopping procedure	2-6	2-4
CHAPTER 3. ORGANIZATIONAL MAINTENANCE INSTRUCTIONS		
Scope of maintenance	3-1	3-1
Preventive maintenance	3-2	3-1
Preventive maintenance checks and service periods	3-3	3-1
Operator's daily preventive maintenance checks and services chart	3-4	3-2
Organizational weekly preventive maintenance checks and services chart	3-5	3-2
Organizational monthly preventive maintenance checks and services chart	3-6	3-2
Organizational quarterly preventive maintenance checks and services chart	3-7	3-2
Cleaning	3-8	3-2
Touchup painting instructions	3-9	3-3
Organizational general troubleshooting information	3-10	3-3
Organizational troubleshooting chart	3-11	3-3
Replacement of indicator lamp and fuses	3-12	3-3
4. FUNCTIONING OF EQUIPMENT		
Circuit description	4-1	4-1
Voltage control description	4-2	4-1
5. DIRECT AND GENERAL SUPPORT TROUBLESHOOTING		
General instructions	5-1	5-1
Organization of troubleshooting procedures	5-2	5-1
Test equipment required	5-3	5-1
Localizing troubles	5-4	5-1
6. REPAIRS AND ADJUSTMENT		
General parts replacement techniques	6-1	6-1
Voltage measurements	6-2	6-1
Internal adjustments	6-3	6-1

	Paragraph	Page
CHAPTER 7. GENERAL SUPPORT TEST PROCEDURES		
General	7-1	7-1
Test equipment and tools	7-2	7-1
Physical tests and inspections	7-3	7-1
Output, regulation, and ripple test	7-4	7-5
Test data summary	7-5	7-7
8. SHIPMENT AND LIMITED STORAGE AND DEMOLITION TO PREVENT ENEMY USE		
Section I. Shipment and limited storage		
Repackaging for shipment or limited storage	8-1	8-1
Packing	8-2	8-1
II. Demolition of materiel to prevent enemy use		
Authority for demolition	8-3	8-1
Methods of destruction	8-4	8-1
Appendix A. REFERENCES		
		A-1
B. MAINTENANCE ALLOCATION		
		B-1
C. ORGANIZATIONAL, DIRECT SUPPORT, AND GENERAL SUPPORT MAINTENANCE REPAIR PARTS AND SPECIAL TOOLS (Deleted)		

CHAPTER 1 INTRODUCTION

Section I. GENERAL

1-1 Scope

a. This manual describes Power Supply PP-2309B/U (fig. 1-1) and provides instruction for installation, operation, and organizational, direct support, and general support categories of maintenance. Power Supply PP-2309B/U is referred to as *power supply* in this manual.

b. Appendix A lists the publications applicable to this equipment. Appendix B lists the maintenance allocation of repair operations to be per-

formed at the appropriate maintenance category.

NOTE

Appendix B is current as of 17 November 1971.

1-2. Indexes of Publications

Refer to the latest issue of DA PAM 310-4 to determine whether there are new editions, changes, additional publications or modification work orders pertaining to the equipment.

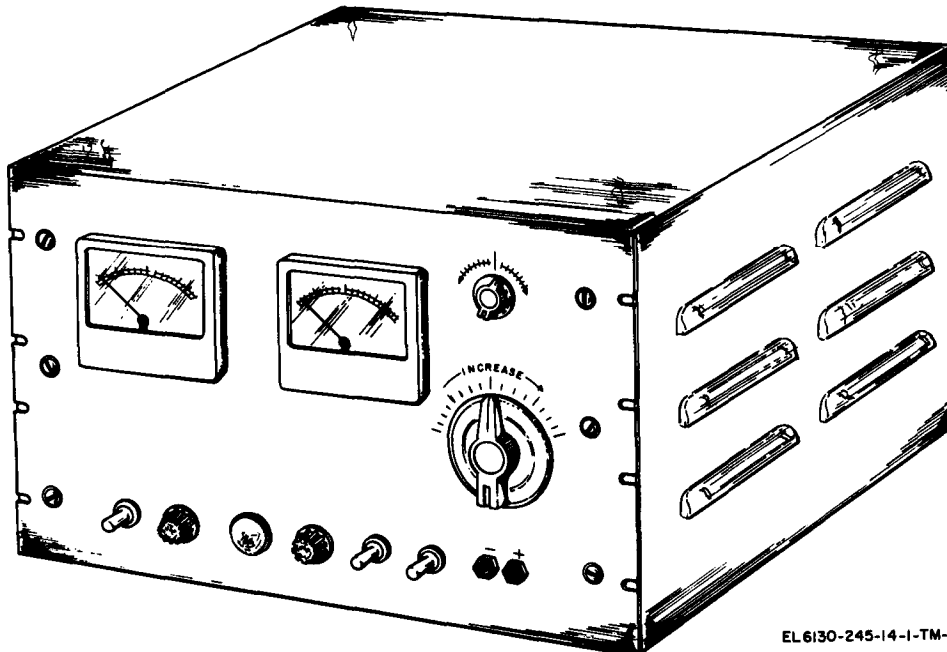

EL 6130-245-14-1-TM-1

Figure 1-1. Power Supply PP-2309B/U, less running spares.

1-3. Maintenance Forms, Records and Reports

a. *Reports of Maintenance and Unsatisfactory Equipment.* Department of the Army forms and procedures used for equipment maintenance will be those prescribed by TM 37-750, The Army Maintenance Management System.

b. *Report of Item and Packaging Discrepancies.* Fill out and forward SF 364 (Report of Discrepancy (ROD)) as prescribed in AR

735-11-2/DLAR 4140.55/NAVMATINST 4355.73/AFR 400-54/MCO 4430.3E.

c. *Discrepancy in Shipment Report (DISREP) (SF 361).* Fill out and forward Discrepancy in Shipment Report (DISREP) (SF 361) as prescribed in AR 55-38/NAVSUPINST 4610.33B/AFR 75-18/MCO 4610.19C and DLAR 4500.15.

d. *Reporting Errors and Recommending Improvements.* You can help improve this manual. If you find any mistakes or if you know of a way to

improve the procedures, please let us know. Mail your letter or DA Form 2028 (Recommended Changes to Publications and Blank Forms) direct to Commander, US Army Communications and Electronics Materiel Readiness Command, ATTN: DRSEL-ME-MQ, Fort Monmouth, NJ 07703. In either case, a reply will be furnished direct to you.

e. *Administrative Storage.* Administrative storage of equipment issued to and used by Army activities will have preventive maintenance performed in accordance with the PMCS charts before storing. When removing the equipment from administrative storage, the PMCS should be performed to assure operational readiness.

Section II. DESCRIPTION AND DATA

1-4. Purpose and Use

Power Supply PP-2309B/U (fig. 1-1) converts 115-volt alternating current (ac), single-phase power, to from 2- to 36-volt direct current (dc) power at a maximum of 15 amperes. This power supply is used in maintenance shops as a general purpose dc power source.

1-5. Technical Characteristics

Power input:

Voltage 115 volts ± 10, 60 Hertz.
 Phase Single.
 Current (full load) 12 amperes maximum.

Power output:

Voltage:
 (RANGE switch set to 5-32V) Variable from 5 to 32 volts.
 (RANGE switch set to 2-36V) Variable from 2 to 36 volts.
 Current 15 amperes maximum.
 Ripple voltage 1 percent root mean square (rms) at 36 volts and full load. (Ripple voltage increases to a maximum of 2 percent rms at 2 volts and full load.)
 Regulation 0.5 percent (RANGE switch set to 5-32V) or 2 percent (RANGE switch set to 2-36V) for voltages between 2 to 5 volts and 32 to 36 volts.

1-6. Components

a. Component.

Item No.	Quantity	Federal stock number	Component	Dimensions (in.)			Volume (cu. ft)	Weight (lb)
				Height	Width	Depth		
1	1	6130-752-2215	Power Supply PP-2309B/U	12¼	19	15	2.04	105

b. Running Spares.

Item No.	Quantity	Federal stock number	Item	Reference designation
1	5	5920-254-7724	Fuse, 12 ampere (12A)	F1
2	5	5920-221-4555	Fuse, 20 ampere (20A)	F2
3	5	5920-280-8342	Fuse, 1-ampere (1A)	F3 and F4
4	1	6240-655-2431	Lamp, indicator	I1

1-7. Description of Equipment

Power Supply PP-2309B/U is a self-contained unit housed in a metal cabinet 19 inches wide, 15 inches deep, and 12¼ inches high. Operating controls are mounted on the front panel. The weight of the power supply is 105 pounds. The input

power cable is mounted at the rear of the equipment and is terminated in a heavy-duty, three-wire, connector plug. Output power terminals are on the front panel and on the rear panel. The power supply is designed for permanent installation in a standard 19 inch equipment rack.

CHAPTER 2 OPERATION

Section I. SERVICE UPON RECEIPT OF EQUIPMENT

2-1. Unpacking

a. Packaging Data. When packed for shipment, Power Supply PP-2309B/U is placed in a carton and packed in a 17- by 24- by 19-inch wooden packing case. A typical wooden packing case and its contents are shown in figure 2-1. The volume is 4.5 cubic feet and the total weight is 155 pounds.

b. Removing Contents.

WARNING

Power Supply PP-2309B/U weighs 105 pounds. Be *careful* when moving. Two people are required for four foot or lower lift. A mechanical carry is needed to move the power supply more than five steps.

(1) Cut and fold back the metal straps.

CAUTION

Do not attempt to pry off the top and side; equipment damage may result.

(2) Remove the nails from the top and one side of the box with a nailpuller. Remove the top and side.

(3) Slide the outer corrugated carton out of the wooden packing case.

(4) Remove the envelope that contains the technical manual.

(5) Remove the outer corrugated carton that is wrapped in the moisture-vaporproof barrier.

(6) Remove the inner corrugated carton that is wrapped in a moisture-vaporproof barrier.

(7) Open the inner corrugated carton.

(8) Remove the equipment.

2-2. Checking Unpacked Equipment

a. Inspect the equipment for damage incurred during shipment. If the equipment has been damaged, report the damage on SF364 (Report of Discrepancy (ROD)) (para 1-3).

b. See that the equipment is complete as listed on the packing slip. If a packing slip is not available, check the equipment against the components data given in paragraph 1-6. Report all discrepancies in accordance with TM 38-750. Shortage of a minor assembly or part that does not affect proper functioning of the equipment should not prevent use of the equipment.

c. If the equipment has been used or recon-

ditioned, see whether it has been changed by a modification work order (MWO). If the equipment has been modified, the MWO number will appear on the front panel near the nomenclature plate. If modified, see that any operational instruction changes resulting from the modification have been entered in the equipment manual.

NOTE

Current MWO applicable to the equipment are listed in DA Pam 310-4.

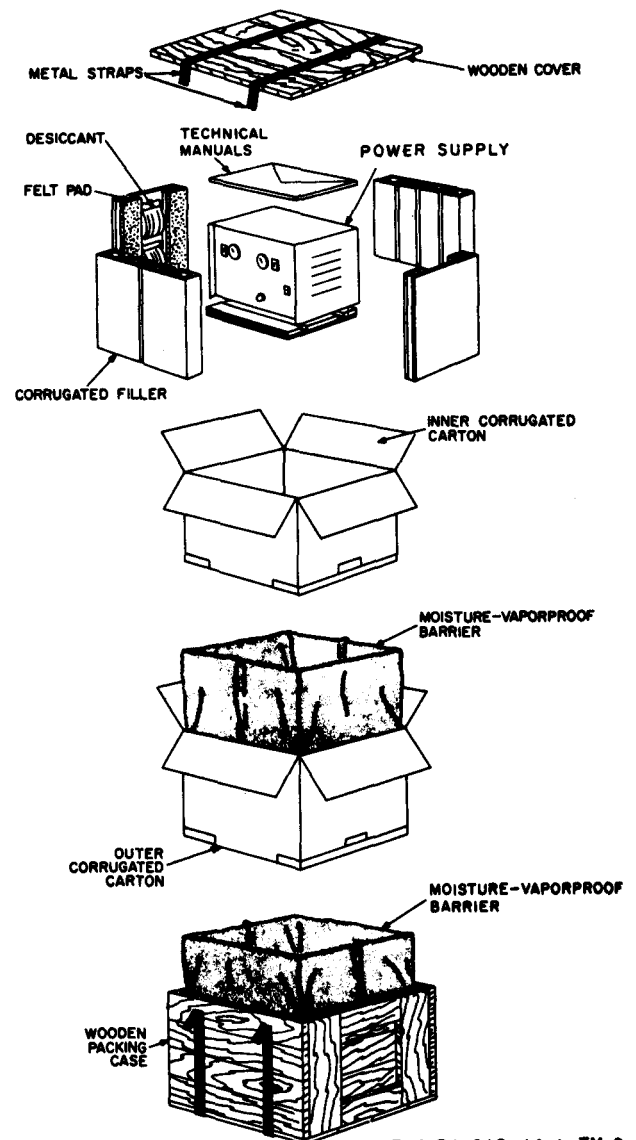

EL6130-245-14-1-TM-2

Figure 2-1. Typical packaging diagram.

Section II. CONTROLS, INDICATORS, AND OPERATING INSTRUCTIONS

2-3. Operating Controls and Indicators (fig. 2-2)

<i>Control indicator, or terminal</i>	<i>Function</i>	<i>Control, indicator, or terminal</i>	<i>Switch position</i>	<i>Function Action</i>
AC INPUT switch	Connects ac input power to power supply when set to ON; disconnects ac input power when set to down position.	RANGE switch (2-position toggle).	2-36V	Provides from 2- to 36-volt dc output power by varying the VOLTAGE CONTROL and VOLTAGE VERNIER controls.
DC OUTPUT switch	When set to ON, connects power supply output power to the - and + terminals on the front and rear panels; when set to down position, disconnects power supply output power to the - and + terminals.		5-32V	Provides from 5- to 32-volt dc output power by varying the

Control, indicator or terminal	Switch position	Function	Action	Control, indicator, or terminal	Function
VOLTAGE CONTROL.	With RANGE switch at 2-36V,	provides a coarse adjustment of 2- to 36-volt dc output.		20A S/B -----	Provides overload protection for the dc output power.
VOLTAGE VERNIER control.	With RANGE switch at 5-32V,	provides a coarse adjustment of 5- to 32-volt dc output.		Fuses (rear panel) : 1A (F3) and 1A (F4) -----	Provides overload protection for the remote sense circuit
VOLTMETER -----	Indicates power supply dc output voltage.			+ terminal (rear panel) on terminal strip TS4.	Provides positive terminal connection to using equipment.
AMMETER -----	Indicates power supply dc output current.			- terminal (rear panel) on terminal strip TS4.	Provides negative terminal connection to using equipment.
Indicator lamp -----	Lights when the power supply is on.			Terminal strip TS3 (rear panel), terminal numbers 1 and 2.	Provides positive terminal connections to using equipment for remote sensing.
+ terminal (front panel).	Provides positive terminal connection to using equipment.			Terminal strip TS3 (rear panel), terminal numbers 3 and 4.	Provides negative terminal connections to using equipment for remote sensing.
- terminal (front panel).	Provides negative terminal connection to using equipment.				
Fuses (front panel) : 12A -----	Provides overload protection for the ac input power.				

2-4. Rear Panel Terminal Strip TS3 Connections (Local and Remote Sense)

a. Local Sense Connections on TS3.

- (1) Install a jumper (supplied with power supply) between terminal 1 and terminal 2.
- (2) Install a jumper (supplied with power supply) between terminal 3 and terminal 4.

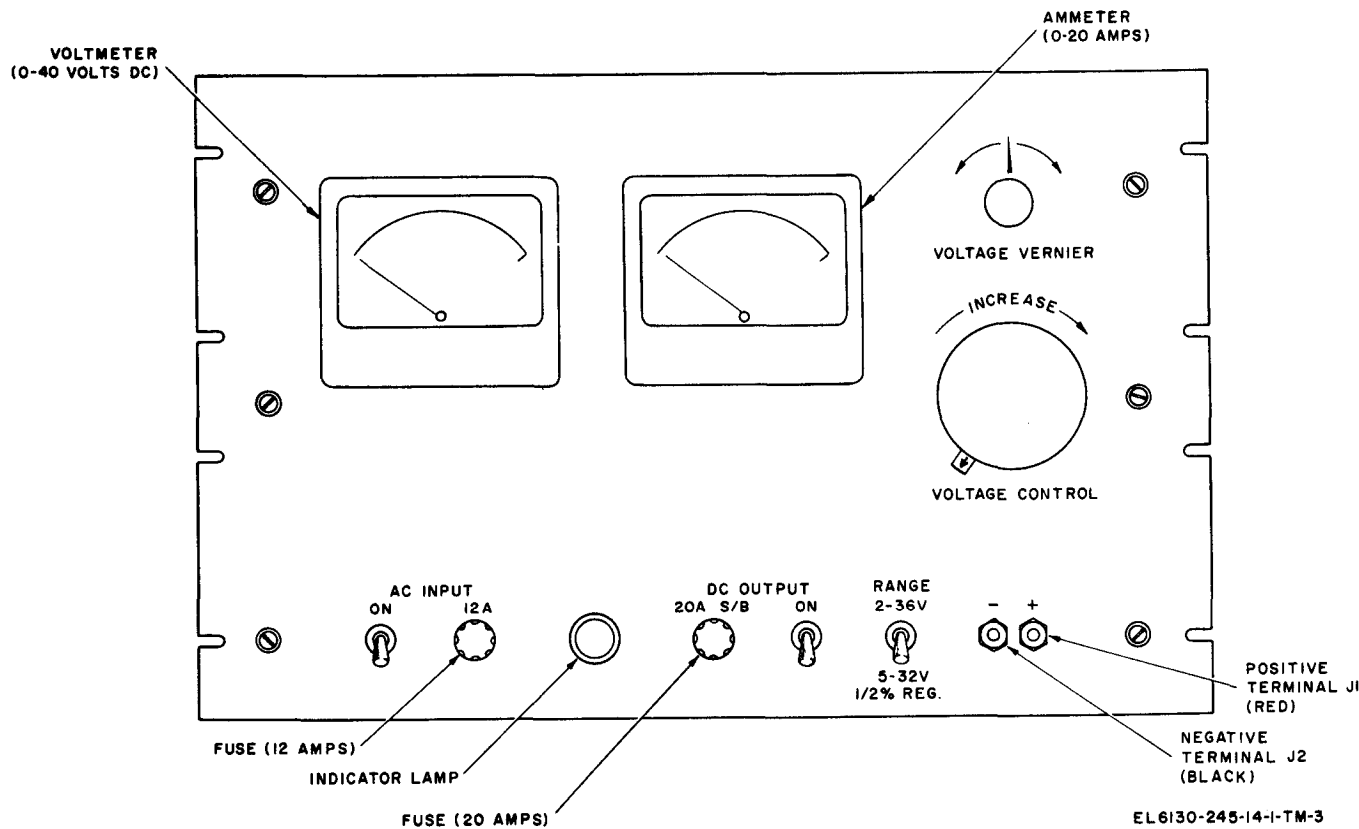

Figure 2-2. Power Supply PP-2309B/U, controls and indicators.

NOTE

Perform the remote sense connections given in *b* below when the equipment to be powered by the power supply is located a distance away (approximately 25 feet) from the power supply. Remote sensing is now necessary to provide the correct voltage value being supplied by the power supply.

b. Remote Sense Connections on TS3.

(1) Remove the jumpers between terminals 1 and 2 and between terminals 3 and 4.

(2) Connect a lead (No. 16 wire) from terminal 2 to the positive input power terminal of the equipment to be powered.

(3) Connect a lead (No. 16 wire) from terminal 3 to the negative input power terminal of the equipment to be powered.

2-5. Operating Procedure

(fig. 2-2)

a. Set the AC INPUT and DC OUTPUT switches to the down (off) position.

b. Rotate the VOLTAGE VERNIER knob until the white line on the knob is at the vertical (midpoint) position.

c. Determine the desired output voltage range. For the output voltage range of 5 to 32 volts dc, set the RANGE switch to 5-32V; for the output voltage range of 2 to 5 volts dc or 32 to 36 volts dc, set the RANGE switch to 2-36V.

d. For local sense operation, perform the proce-

dures given in paragraph 2-4a. For remote sense operation, perform the procedures given in paragraph 2-4b.

CAUTION

Before making connections given in *e* below, be sure the input power switch on the equipment to be powered is in the off position.

e. Connect the - terminal on the power supply front panel to the negative input power terminal on the equipment to be powered. Connect the + terminal on the power supply front panel to the positive input power terminal on the equipment to be powered. (In addition, terminal strip TS4 on the power supply rear panel can be used to connect the output power of the power supply to the equipment to be powered.)

f. Set the AC INPUT switch to ON and adjust the VOLTAGE CONTROL to as close as possible to the exact voltage required by the equipment to be powered; then adjust the VOLTAGE VERNIER knob to the exact voltage required by the equipment to be powered.

g. Set the DC OUTPUT switch to ON. Turn the equipment to be powered to ON. (Periodically observe that the power supply output is correct.)

2-6. Stopping Procedure

a. Set the DC OUTPUT switch to the down (off) position.

b. Set the AC INPUT switch to the down (off) position.

CHAPTER 3

ORGANIZATIONAL MAINTENANCE INSTRUCTIONS

3-1. Scope of Maintenance

The maintenance duties assigned to the operator and organizational repairman of the equipment are listed below together with a reference to the paragraphs covering the specific maintenance functions.

a. Operator's daily preventive maintenance checks and services (para 3-4).

b. Organizational weekly preventive maintenance checks and services (para 3-5).

c. Organizational monthly preventive maintenance checks and services (para 3-6).

d. Organizational quarterly preventive maintenance checks and services (para 3-7).

e. Cleaning (para 3-8).

f. Touchup painting (para 3-9).

g. Organizational troubleshooting (para 3-10 and 3-11).

h. Replacement of indicator lamp and fuses (para 3-12).

3-2. Preventive Maintenance

Preventive maintenance is the systematic care, servicing, and inspection of equipment to prevent the occurrence of trouble, to reduce downtime, and to assure that the equipment is serviceable.

a. Systematic Care. The procedures given in paragraphs 3-4 through 3-8 cover routine systematic care and cleaning essential to proper upkeep and operation of the equipment.

b. Preventive Maintenance Checks and Services. The preventive maintenance checks and services charts (para 3-4 through 3-7) outline functions to be performed at specific intervals. These checks and services are to maintain Army electronic equipment in a combat serviceable condition; that is, in good general (physical) condition and in good operating condition. To assist operators in maintaining combat serviceability, the chart indicates what to check, how to check, and the normal indications. The *References* column lists the paragraphs or manuals that contain detailed repair or replacement procedures. If the defect cannot be remedied by performing the corrective actions listed, higher category of maintenance or repair is required. Records and reports of these checks and services must be made in accordance with the requirements set forth in TM 38-750.

3-3. Preventive Maintenance Checks and Service Periods

Preventive maintenance checks and services of the equipment are required daily, weekly, monthly, and quarterly.

a. Paragraph 3-4 specifies checks and services that must be accomplished daily (or at least once each week if the equipment is maintained in standby condition).

b. Paragraphs 3-5, 3-6, and 3-7 specify *additional* checks and services that must be performed weekly, monthly, and quarterly.

3-4. Operator's Daily Preventive Maintenance Checks and Services Chart

<i>Sequence No.</i>	<i>Item to be inspected</i>	<i>Procedure</i>	<i>References</i>
1	Completeness	See that the equipment is complete.	(Para 1-6.)
2	Exterior surfaces	Clean the exterior surfaces, including the panel and meter glasses (para 3-8). Check all meter glasses and indicator lenses for cracks.	
3	Connectors	Check the tightness of all connectors.	
4	Power supply operation	During operation, be alert for any abnormal indication.	(Para 2-5.)

3-5. Organizational Weekly Preventive Maintenance Checks and Services Chart

<i>Sequence No.</i>	<i>Item to be inspected</i>	<i>Procedure</i>	<i>References</i>
1	Cable	Inspect cable for chafed, cracked, or frayed insulation. Replace connector that is broken, arced, stripped, or worn excessively.	
2	Metal surfaces	Inspect exposed metal surfaces for rust and corrosion. Clean and touchup paint as required.	(Para 3-9.)

3-6. Organizational Monthly Preventive Maintenance Checks and Services Chart

<i>Sequence No.</i>	<i>Item to be inspected</i>	<i>Procedure</i>	<i>References</i>
1	Transformer terminals	Inspect terminals on power transformer. All nuts must be tight. There should be no evidence of dirt or corrosion.	None.
2	Terminal blocks	Inspect terminal blocks for loose connections and cracked or broken insulation.	
3	Gaskets and insulators	Inspect gaskets, insulators, bushings, and sleeves for cracks, chipping, and excessive wear.	
4	Interior	Clean interior of chassis and cabinet.	

3-7. Organizational Quarterly Preventive Maintenance Checks and Services Chart

<i>Sequence No.</i>	<i>Item to be inspected</i>	<i>Procedure</i>	<i>References</i>
1	Publications	See that all publications are complete, serviceable, and current.	DA Pam 310-4.
2	Modifications	Check DA Pam 310-4 to determine if new applicable MWO have been published. All URGENT MWO must be applied immediately. All NORMAL MWO must be scheduled.	TM 38-750 and DA Pam 310-4.
3	Spare parts	Check spare parts for general condition and method of storage. No overstock should be evident and all shortages must be on valid requisitions.	(Para 1-6b.)

3-8. Cleaning

Inspect the exterior of the equipment. The exterior surfaces should be free of dust, dirt, grease, and fungus.

a. Remove dust and loose dirt with a clean, soft cloth.

WARNING

Adequate ventilation should be provided while using TRICHLORO-TRIFLUOROETHANE. Prolonged breathing of vapor should be avoided. The solvent should not be used near

heat or open flame; the products of decomposition are toxic and irritating. Since TRICHLOROTRIFLUOROETHANE dissolves natural oils, prolonged contact with skin should be avoided. When necessary, use gloves which the solvent cannot penetrate. If the solvent is taken internally, consult a physician immediately.

b. Remove grease, fungus, and ground-in dirt from the case; use a cloth dampened (not wet) with trichlorotrifluoroethane.

c. Remove dust or dirt from output terminals with a brush.

CAUTION

Do not press on the meter faces (glasses) when cleaning; the meters may become damaged.

d. Clean the front panel, meters, and control knobs; use a soft, clean cloth. If necessary, dampen the cloth with water; mild soap may be used for more effective cleaning.

3-9. Touchup Painting Instructions

Remove rust and corrosion from metal surfaces by lightly sanding them with fine sandpaper. Brush two thin coats of paint on the bare metal

to protect it from further corrosion. Refer to applicable cleaning and refinishing practices specified in TB 746-10.

3-10. Organizational General Troubleshooting Information

Troubleshooting the power supply at the organizational category is based on an operational check. To troubleshoot the power supply, perform the operation functions until an abnormal indication or result is observed; then, perform checks and corrective actions indicated in the troubleshooting chart. If the corrective measures indicated do not result in the correction of the trouble, higher maintenance category repair is required.

3-11. Organizational Troubleshooting Chart

Item No.	Trouble symptom	Probable trouble	Checks and corrective measures
1	Indicator lamp does not illuminate when AC POWER switch is set to ON.	a. Defective input power cable or cable connector. b. Defective AC INPUT switch _ _ _ _ c. Front panel fuse 12A (12-ampere) open. d. Defective indicator lamp _ _ _	a. Check continuity of cable and connector; replace or repair as required. b. Higher maintenance category repair is required. c. Replace defective fuse (para 3-12b). d. Replace defective lamp (para 3-12a).
2	VOLTMETER indicates 0 with AC INPUT switch set to ON.	Defective VOLTMETER _ _ _ _ _	Higher maintenance category repair is required.
3	With power supply powering equipment, AMMETER indicates 0.	AMMETER is defective _ _ _ _	Higher maintenance category repair is required.
4	With power supply powering equipment in remote sense operation, VOLTMETER indicates 0.	Either of the two rear panel fuses 1A (1-ampere) is open.	Replace defective fuse (para 3-12b).

3-12. Replacement of Indicator Lamp and Fuses

a. *Indicator Lamp.* Turn the glass indicator jewel counterclockwise and pull it out to expose the defective lamp. Press in on the indicator lamp and turn it counterclockwise to unlock it. Pull the defective indicator lamp out and replace it with

a new one. Push the indicator lamp in and twist it clockwise to lock it. Replace the glass indicator jewel.

b. *Fuses.* Unscrew the fuseholder cap and remove the defective fuse. Be sure to replace fuse with an exactly rated duplicate. Replace the fuse holder cap.

CHAPTER 4

FUNCTIONING OF EQUIPMENT

4-1. Circuit Description

a. The ac line voltage is partially absorbed by saturable reactor SR1. The remaining ac line voltage is applied across the primary of transformer T3. The primary voltage of transformer T2 is varied by variable transformer T1. The secondary voltages of transformers T2 and T3 are rectified by diode bridge CR1 and filtered by filter choke L1 and capacitor C1. The rectified and filtered dc output is applied to the load. The voltage supplied to the primary of T2 by T1 on the VOLTAGE CONTROL setting. The amount of voltage applied to rectifier CR1 for a given VOLTAGE CONTROL setting determines the magnitude of the dc voltage available at the output terminals.

b. The magnitude of the current through saturable reactor SR1 control winding (terminals 5 and 6) determines the amount of voltage absorbed by the saturable reactor. The current through this winding automatically adjusts itself to the magnitude required to maintain equilibrium voltage. High gain is achieved through the rectangu-

lar hysteresis loop characteristics of the magnetic core material of the saturable reactor and the self-saturation feedback provided by rectifiers CR2 and CR3.

4-2. Voltage Control Description

a. The reference circuit consists of constant voltage transformer T4, capacitor C3, stepdown transformer T5, rectifier CR4, filter choke L2, capacitor C4 and voltage divider network R5, R6, R7, and R8. The reference voltage appears between the slider on R6 and the slider on R8. This voltage is approximately equal to the dc output voltage, differing only by the voltage drop across the control winding of saturable reactor SR1.

b. If the dc output voltage tends to increase, the current through the control winding of SR1 increases, causing SR1 to absorb more voltage, thus lowering the dc output voltage of the power supply. A reduction in output voltage has the opposite effect.

CHAPTER 5

DIRECT AND GENERAL SUPPORT TROUBLESHOOTING

WARNING

When servicing the power supply, be extremely careful of the high voltages.

5-1. General Instructions

Troubleshooting at the direct support and general support maintenance categories includes all the techniques outlined for organizational maintenance and any special or additional techniques required to isolate a defective part. Paragraph 5-4d provides the troubleshooting chart to be used by the repairman.

5-2. Organization of Troubleshooting Procedures

a. General. The first step in servicing a defective power supply is to localize the fault, which means tracing the fault to a defective circuit responsible for the abnormal indication. The second step is to isolate the fault, which means locating defective part or parts. Some defective parts, such as burned resistors and shorted transformers, can often be located by sight, smell, and hearing. Most defective parts, however, must be isolated by checking voltages and resistance.

b. Localization and Isolation. The first step in tracing trouble is to locate the circuit or part at fault by the following methods:

(1) **Visual inspection.** The purpose of visual inspection is to locate faults without testing or measuring circuits. All meter indications or other visual signs should be observed and an attempt made to localize the fault to a particular part.

(2) **Operational test.** Operational tests frequently indicate the general location of trouble. In many instances, the test will help in determining the exact nature of the fault.

(3) **Troubleshooting chart.** The troubleshooting chart (para 5-4d) lists symptoms of common

troubles and gives (or references) corrective measures. Such a chart obviously cannot include all trouble symptoms that may occur. The repairman should use this chart as a guide in analyzing symptoms that may not be listed.

(4) **Resistor and capacitor color code diagrams.** Color code diagrams for resistors, capacitors, and inductors (fig. 8-1) provide pertinent resistance, voltage rating, and tolerance information.

5-3. Test Equipment Required

Multimeter TS-352B/U is required for troubleshooting. Multimeter TS-352B/U is used for continuity tests, resistance measurements, and ac or dc voltage measurements.

5-4. Localizing Troubles

a. General. In the troubleshooting chart (*d* below), procedures are outlined for localizing troubles and for isolating troubles within the various circuits of the power supply. Refer to figures 5-1 and 5-2 for parts location. Refer to the schematic diagram (fig. 5-3) to identify circuit components and for point-to-point circuit wiring and connections. Depending on the nature of the operational symptoms, one or more of the localizing procedures will be necessary. When trouble has been localized to a particular circuit, use voltage and resistance measurements to isolate the trouble to a particular part.

b. Use of Chart. When an abnormal symptom has been observed in the equipment, look for a description of this symptom in the *Symptom* column and perform the corrective measure shown in the *Corrective measures* column.

c. Conditions to Tests. All checks outlined in the troubleshooting chart are to be conducted with the power supply connected to a power source (no load connected to output terminals).

d. Troubleshooting Chart.

<i>Symptom</i>	<i>Probable trouble</i>	<i>Corrective measures</i>
1. Indicator lamp I1 does not light when AC INPUT switch is set to ON.	No ac power is applied to the power supply. Defective AC INPUT switch _____	Check for input voltage. Check switch; replace if defective.
2. Indicator lamp I1 lights but no output voltage is present.	Open in output circuit _____ Defective component in output circuit _	Check for loose connections and broken lead. Check components; replace if defective.
3. Output voltage range of 5 to 32 volts dc cannot be obtained with RANGE switch set to 5-32V.	Resistor R5 slider with blue lead and resistor R7 slider with gray lead improperly positioned.	Perform adjustment procedures given in paragraph 6-3.
4. Output voltage range of 2 to 36 volts dc cannot be obtained with RANGE switch set to 2-36V.	Resistor R5 slider with yellow lead and resistor R7 slider with green lead improperly positioned.	Perform adjustment procedures given in paragraph 6-3.

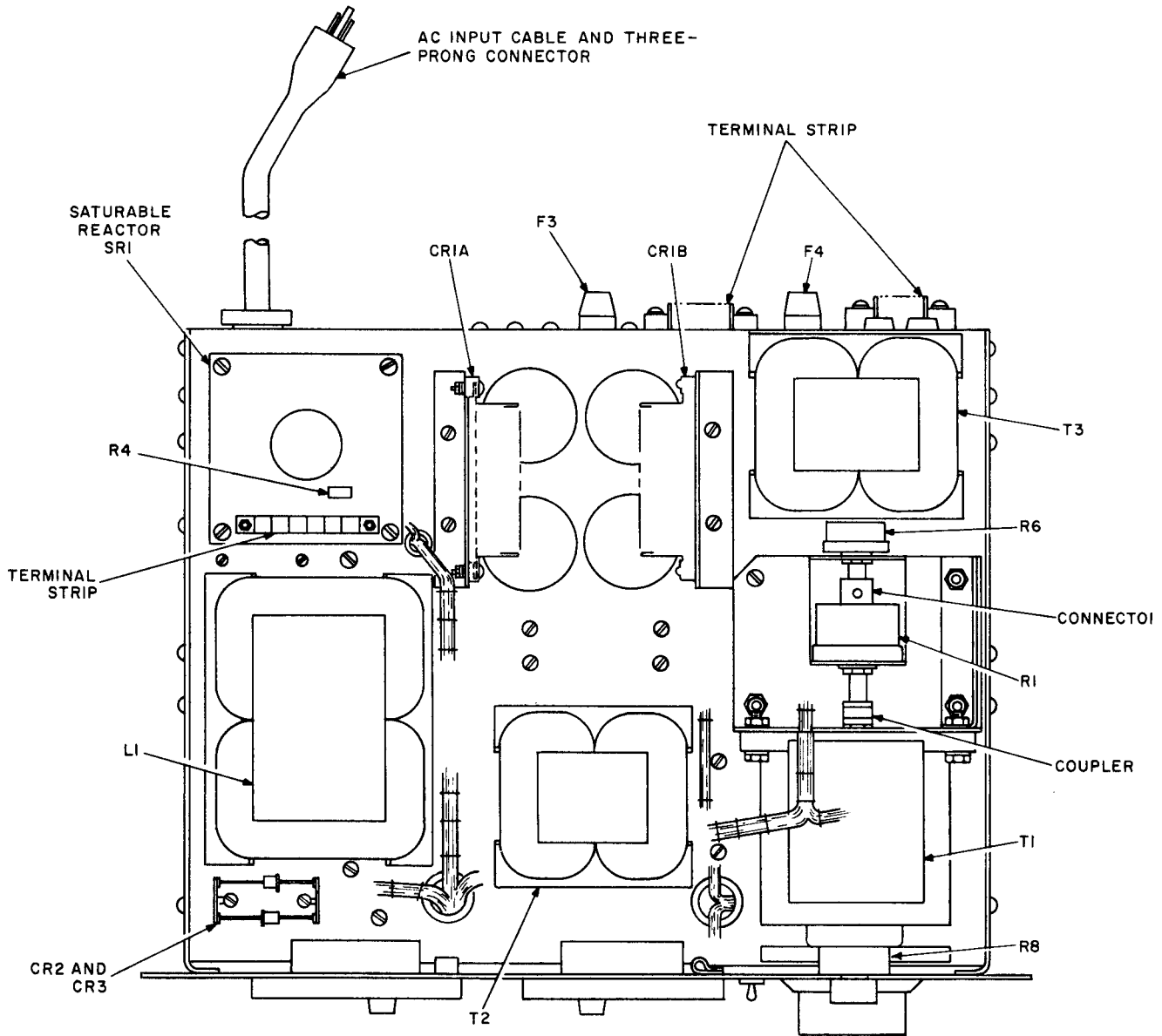

EL 6130-245-14-I-TM-4

Figure 5-1. Parts location diagram, top view, front.

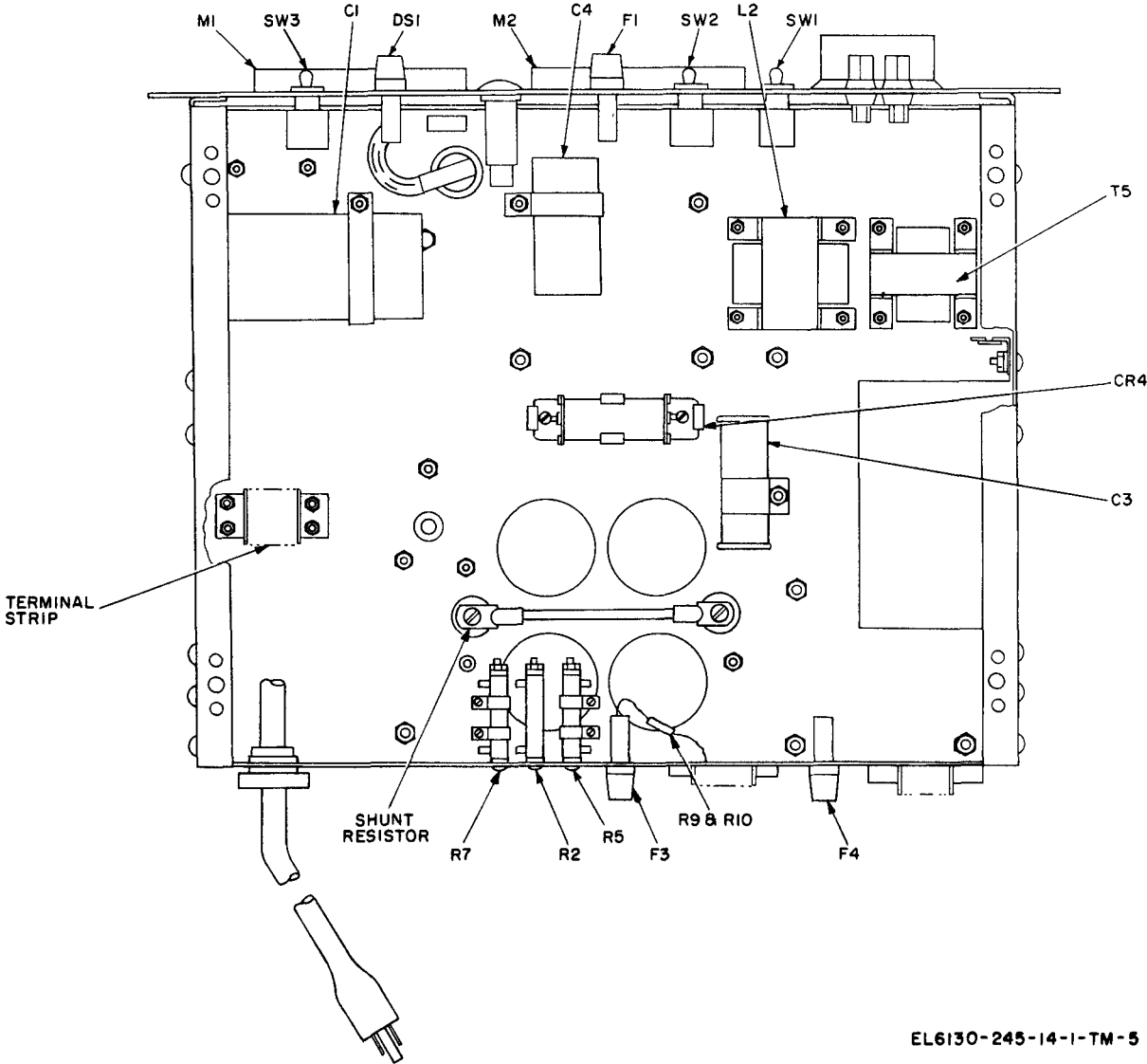

EL6130-245-14-1-TM-5

Figure 5-2. Parts location diagram, top view, rear.

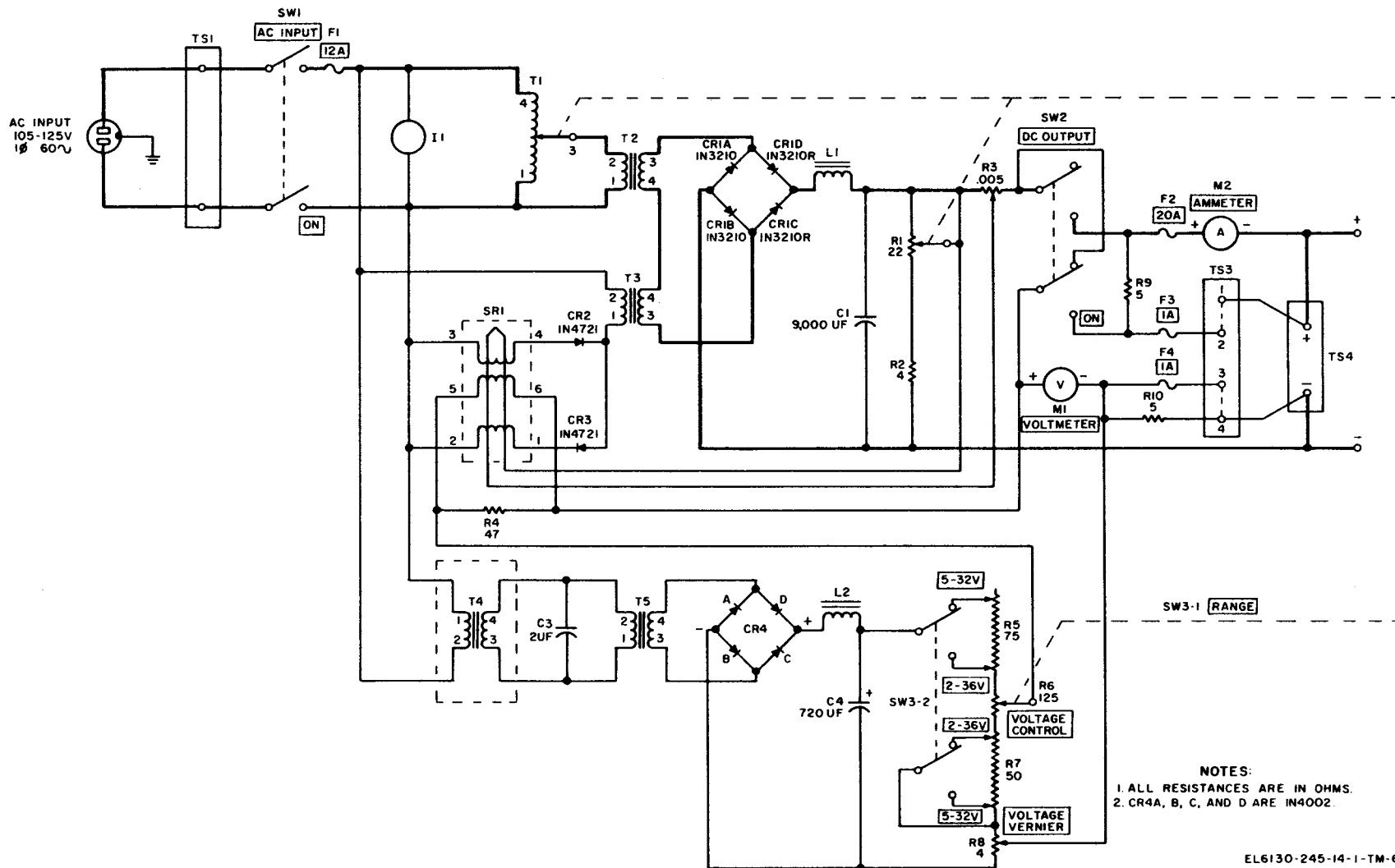

Figure 5-3. Power Supply PP-2309B/U, schematic diagram.

CHAPTER 6

REPAIRS AND ADJUSTMENT

6-1. General Parts Replacement Techniques

The power supply parts can be reached and replaced easily without special procedures. Refer to figures 5-1 and 5-2 for the location of parts. When soldering connections to the diodes, solder quickly; use a heat sink (such as long-nosed pliers) between the soldered joint and the diode.

6-2. Voltage Measurements

Perform the voltage checks shown in the chart below with 115-volt ac input and 28-volt dc output. The voltage checks are provided as an aid in troubleshooting and are approximate values.

<i>Test points</i>	<i>Ac voltage (no load)</i>	<i>Ac voltage (15-ampere load)</i>
T2-3 to T2-4	30	27
T3-3 to T3-4	16	19
T5-3 to T5-4	52	52
SR1-1 to SR1-2	105	46
SR1-3 to SR1-4	105	46

6-3. Internal Adjustments

Perform the following adjustments when the power supply output does not provide a range of 5 to 32 volts with the RANGE switch set to 5-32V, or 2 to 36 volts with the RANGE switch set to 2-36V.

WARNING

Do not touch the power supply interior components unless the AC POWER switch is set to the off (down) position.

a. Check the brush position of tandem rheostat R6 ganged to transformer T1 (powerstat). With the VOLTAGE CONTROL fully clockwise, rheostat R6 (mounted nearest to the rear of the unit)

should have its brush centered on the last turn of the resistance wire.

b. Set RANGE switch to 5-32V, VOLTAGE CONTROL fully counterclockwise, and VOLTAGE VERNIER knob to center position; adjust the slider with the gray lead on R7 until 5 volts is obtained on the VOLTMETER.

c. Set the VOLTAGE CONTROL fully clockwise, VOLTAGE VERNIER knob to center position, and RANGE switch to 5-32V; adjust the slider with the blue lead on R5 until 32 volts is obtained on the VOLTMETER.

d. Set RANGE switch to 2-36V, VOLTAGE CONTROL fully counterclockwise, and VOLTAGE VERNIER knob to center position; adjust the slider with the green lead on R7 until 2 volts is obtained on the VOLTMETER.

e. Set RANGE switch to 2-36V, VOLTAGE CONTROL fully clockwise, and VOLTAGE VERNIER knob to center position; adjust the slider with the yellow lead on R5 until 36 volts is obtained on the VOLTMETER.

f. Set RANGE switch to 5-32V and adjust the VOLTAGE CONTROL and VOLTAGE VERNIER knob for a 32-volt indication on the VOLTMETER. Set the DC OUTPUT switch to off (down) position and connect a 15-ampere load to the + and - terminals on the front panel. Set the DC OUTPUT switch to ON and observe the indication on the VOLTMETER. If the VOLTMETER indicates 30.5 volts or greater, regulation is within the correct limit. If the VOLTMETER indicates less than 30.5 volts, adjust load compensation shunt resistor R3 until the output voltage, under load is between 30.5 and 32 volts.

CHAPTER 7

GENERAL SUPPORT TEST PROCEDURES

7-1. General

a. Testing procedures are prepared for use by Signal Field Maintenance Shops and Signal Service Organizations responsible for general support maintenance of electronic equipment to determine the acceptability of repaired equipment. These procedures set forth specific requirements that repaired equipment *must* meet before it is returned to the using organization. These procedures may also be used as a guide for testing equipment that has been repaired at direct support if the proper tools and test equipments are available. A summary of the performance standards is given in paragraph 7-5.

a. Test Equipment.

<i>Nomenclature</i>	<i>Federal stock No.</i>	
Voltmeter, Digital AN/GSM-64 _____	6625-870-2264 _____	TM 11-6625-444-15
Multimeter TS-352B/U _____	6625-553-0142 _____	TM 11-6625-366-15
Multimeter, Weston Instruments Model 281 _____	6625-356-8306 _____	None.
Transformer, Variable Power TF-171A/USM _____	5950-506-0632 _____	None.
Voltmeter, Meter ME-30A/U _____	6625-643-1670 _____	TM 11-6625-320-12
Resistor, variable, wirewound (0- to 7.5-ohm, 1,000-watt) _____	5905-195-4496 _____	None.

b. Tools. All the tools required are included in Tool Kit, Electronic Equipment TK-100/G.

7-3. Physical Tests and Inspections

a. Test Equipment and Materials. None re-

b. Comply with the instructions preceding each chart before proceeding to the chart. Perform each step in sequence. Do not vary the sequence. For each step, perform all the actions required in the *Control settings* columns; then perform each specific test procedure and verify it against its performance standard.

7-2. Test Equipment and Tools

All test equipment and tools required to perform the testing procedures given in this chapter are listed in *a* and *b* below.

quired.

b. Test Connections and Condition. Noconnections necessary.

c. Procedure.

<i>Step No.</i>	<i>Test equipment</i>	<i>Control settings</i> <i>Equipment under test</i>	<i>Test procedure</i>	<i>Performance standard</i>
1	None	Controls may be in any position	<p><i>a.</i> Inspect case and chassis for damage, missing parts, and condition of paint.</p> <p style="text-align: center;">NOTE</p> <p>Touchup painting is recommended in lieu of refinishing whenever practical; screw-heads, binding posts, receptacles, and other plated parts will not be painted or polished with abrasives.</p> <p><i>b.</i> Inspect all controls and mechanical assemblies for loose or missing screws, bolts, and nuts.</p> <p><i>c.</i> Inspect socket and meters for looseness, damage, or missing parts.</p>	<p><i>a.</i> No damage evident or parts missing. External surfaces intended to be painted will not show bare metal. Panel lettering will be legible.</p> <p><i>b.</i> Screws, bolts, and nuts will be tight. None missing.</p> <p><i>c.</i> No loose parts or damage. No missing parts.</p>
2	None	Controls may be in any position	<p><i>a.</i> Rotate VOLTAGE CONTROL and VOLTAGE VERNIER throughout their limits of travel.</p> <p><i>b.</i> Operate AC INPUT and DC INPUT switches.</p>	<p><i>a.</i> Switch will rotate freely without binding or excessive looseness.</p> <p><i>b.</i> Switches will operate properly.</p>

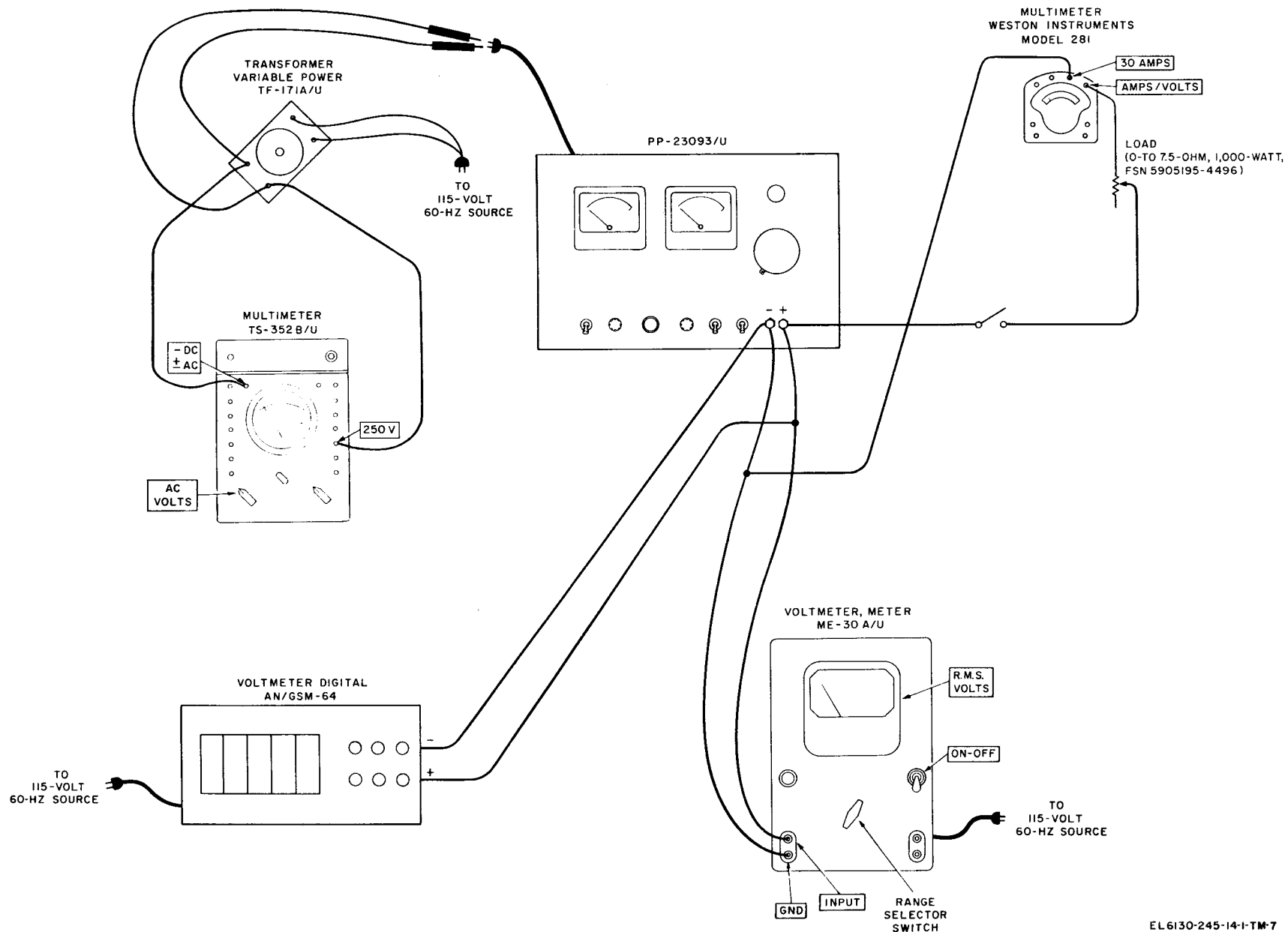

Figure 7-1. Output, regulation, and ripple test setup.

EL 6130-245-14-I-TM-7

7-4. Output, Regulation, and Ripple Test

a. Test Equipment and Materials.

- (1) Voltmeter, Meter ME-30A/U.
- (2) Multimeter, TS-352B/U.
- (3) Transformer, Variable Power TF - 171A/USM.
- (4) Multimeter, Weston Instruments Model

281.

(5) Voltmeter, Digital AN/GSM-64.

(6) Resistor, variable, wirewound (0- to 7.5-ohm, 1,000-watt).

b. *Test Connections and Conditions.* Connect the equipment as shown in figure 7-1. Connect TF-171A/USM to a 115-volt ac source.

c. Procedure

Control settings

Step No.	Test equipment	Equipment under test	Test procedure	Performance standard
	TF-171A/USM Control: 115 ME-30A/U ON-OFF switch: ON Range selector switch: 1 TS-352B/U Function: AC VOLTS AN/GSM/64 Power switch: ON Function switch: DC Mode switch: AUTO	AC INPUT switch: OFF DC OUTPUT switch: OFF RANGE switch: 5-32V VOLTAGE VERNIER: center position. VOLTAGE CONTROL: Fully counterclockwise.	<ol style="list-style-type: none"> a. Adjust the control on the TF-171A/USM for 115-volt ac output. b. Set AC INPUT switch on PP-2309B/U to ON and adjust VOLTAGE CONTROL and VOLTAGE VERNIER knob for an indication of 32 volts on PP-2309B/U. c. Close the switch in series with the load, set the DC OUTPUT switch to ON, and adjust the load for an indication of 15 amperes on Multimeter, Model 281. d. Set DC OUTPUT switch to OFF (down) position and open the switch in series with load. 	<ol style="list-style-type: none"> a. None. b. VOLTMETER on PP-2309B/U indicates between 31.5 and 32.5 volts. c. AN/GSM-64 indicates a minimum of 4.9 volts. ME-30A/U indicates 0.05 volt RMS maximum. AMMETER on PP-2309B/U indicates between 14 and 16 amperes. d. None.
2	ME-30A/U ON-OFF switch On Range selector switch: .1 All other control settings are as step 1.	Same as step 1 ..	<ol style="list-style-type: none"> a. Adjust the control on the TF-171A/USM for 115-volt ac output. b. Adjust VOLTAGE CONTROL and VOLTAGE VERNIER knob for an indication of 5 volts on PP-2309B/U. c. Close the switch in series with the load, set the DC OUTPUT switch to ON, and adjust the load for an indication of 15 amperes on Multimeter, Model 281. d. Set DC OUTPUT switch to OFF (down) position and open the switch in series with load. 	<ol style="list-style-type: none"> a. None. b. VOLTMETER on PP-2309B/U indicates between 4.5 and 5.5 volts. c. AN/GSM-64 indicates a minimum of 4.9 volts. ME-30A/U indicates 0.05 volt rms maximum. AMMETER on PP-2309B/U indicates between 14 and 16 amperes. d. None.
3	Same as step 1 . . .	Same as step 1 . . .	<ol style="list-style-type: none"> a. Adjust the control on the TF-171A/USM for 105-volt ac output. b. Set the AC INPUT switch on PP-2309B/U to ON and adjust VOLTAGE CONTROL and VOLTAGE VERNIER knob for an indication of 32 volts on VOLTMETER of PP-2309B/U. c. Adjust the VOLTAGE CONTROL and VOLTAGE VERNIER knob for an indication of 5 volts on VOLTMETER of PP-2309B/U. d. Adjust the control on the TF-171A/USM for 125-volt ac output. e. Adjust the VOLTAGE CONTROL and VOLTAGE VERNIER knob for an indication of 32 volts on VOLTMETER of PP-2309B/U. f. Adjust the VOLTAGE CONTROL and VOLTAGE VERNIER knob for an indication of 5 volts on VOLTMETER of PP-2309B/U. 	<ol style="list-style-type: none"> a. None. b. VOLTMETER on PP-2309B/U indicates 32 volts. c. VOLTMETER on PP-2309B/U indicates 5 volts. d. None. e. VOLTMETER on PP-2309B/U indicates 32 volts. f. VOLTMETER on PP-2309B/U indicates 5 volts.

Control settings

Step
No.

Test equipment

Equipment under test

Test procedure

Performance standard

			g. Set the AC INPUT switch to OFF (down) position, and open switch in series with the load.	g. None.
4	Same as step 1	RANGE switch: 2-36V. All other control settings are same as step 1.	<p>a. Adjust the control on the TF-171A/USM for a 115-volt ac output.</p> <p>b. Set AC INPUT switch on PP-2309B/U to ON and adjust VOLTAGE CONTROL and VOLTAGE VERNIER knob for an indication of 36 volts on PP-2309B/U.</p> <p>c. Close the switch in series with the load, set the DC OUTPUT switch to ON, and adjust the load for an indication of 15 amperes on Multimeter, Model 281.</p> <p>d. Set DC OUTPUT switch to OFF (down) position and open switch in series with the load.</p>	<p>a. None.</p> <p>b. VOLTMETER on PP-2309B/U indicates between 35 and 37 volts.</p> <p>c. AN/GSM-64 indicates a minimum of 35.2 volts. ME-30A/U indicates 0.36 volt rms maximum. AMMETER on PP-2309B/U indicates between 14 and 16 amperes.</p> <p>d. None.</p>
5	ME-30A/U ON-OFF switch: ON RANGE selector switch: .1 All other control settings are same as in step 1.	Same as step 4	<p>a. Adjust the control on the TF-171A/USM for a 115-volt ac output.</p> <p>b. Set AC INPUT switch on PP-2309B/U to ON and adjust VOLTAGE CONTROL and VOLTAGE VERNIER knob for an indication of 2 volts on PP-2309B/U.</p> <p>c. Close the switch in series with the load, set the DC OUTPUT switch to ON, and adjust the load for an indication of 15 amperes on Multimeter, Model 281.</p> <p>d. Set DC OUTPUT switch to OFF (down) position and open switch in series with the load.</p>	<p>a. None.</p> <p>b. VOLTMETER on PP-2309B/U indicates between 1.9 and 2.1 volts.</p> <p>c. AN/GSM-64 indicates a minimum of 1.96 volts. ME-30A/U indicates 0.04 volt rms maximum. AMMETER on PP-2309B/U indicates between 14 and 16 amperes.</p> <p>d. None.</p>
6	Same as step 1	Same as step 4	<p>a. Adjust the control on the TF-171A/USM for 105-volt ac output.</p> <p>b. Set the AC INPUT switch on PP-2309B/U to ON and adjust VOLTAGE CONTROL and VOLTAGE VERNIER knob for an indication of 36 volts on VOLTMETER of PP-2309B/U.</p> <p>c. Adjust the VOLTAGE CONTROL and VOLTAGE VERNIER knob for an indication of 2 volts on VOLTMETER of P-2309B/U.</p> <p>d. Adjust the control on the TF-171A/USM for 125-volt ac output.</p> <p>e. Adjust the VOLTAGE CONTROL and VOLTAGE VERNIER knob for an indication of 36 volts on VOLTMETER of PP-2309B/U.</p> <p>f. Adjust the VOLTAGE CONTROL and VOLTAGE VERNIER knob for an indication of 2 volts on VOLTMETER of PP-2309B/U.</p> <p>g. Set the AC INPUT switch to OFF (down) position, and disconnect the equipment.</p>	<p>a. None.</p> <p>b. VOLTMETER on PP-2309B/U indicates 36 volts.</p> <p>c. VOLTMETER on PP-2309B/U indicates 2 volts.</p> <p>d. None.</p> <p>e. VOLTMETER on PP-2309B/U indicates 36 volts.</p> <p>f. VOLTMETER on PP-2309B/U indicates 2 volts.</p> <p>g. None.</p>

7-5. Test Data Summary

a. *Input.*

(1) Voltage ----- 115 volts \pm 10.

(2) Frequency ----- 60 Hz.

(3) Phase ----- Single.

b. *Output.*

<i>RANGE switch setting</i>	<i>Output voltage</i>	<i>Ripple voltage (maximum)</i>	<i>Minimum voltage under full load of 15 amperes (regulation)</i>
5-32V -----	32 -----	0.32 -----	31.8 -----
5-32V -----	5 -----	0.05 -----	4.9 -----
2-36V -----	36 -----	0.35 -----	35.2 -----
2-36V -----	2 -----	0.04 -----	1.96 -----

CHAPTER 8

SHIPMENT AND LIMITED STORAGE AND DEMOLITION TO

PREVENT ENEMY USE

Section I. SHIPMENT AND LIMITED STORAGE

8-1. Repackaging for Shipment or Limited Storage

The exact procedure for repackaging depends on the material available and the conditions under which the equipment is to be shipped or stored. Adapt the procedure outlined below whenever circumstances permit. The information concerning the original packaging (para 2-1) will also be helpful.

a. Material Requirements. The following materials are required for packaging the power supply. For stock numbers of materials, refer to SB 38-100.

<i>Material</i>	<i>Quantity</i>
Corrugated, single-faced flexible paper _ _ _ _	90 sq ft
Gummed paper tape _ _ _ _ _ _ _ _ _ _	40 ft
Pressure-sensitive tape _ _ _ _ _ _ _ _	35 ft
Waterproof paper	90 sq ft
Wooden packing case (17 x 24 x 19 in.) _ _ _	1

b. Packaging (fig. 2-1). Package the items of the power supply as outlined below.

(1) *Main unit.* Cushion the main unit on all sides with fillers and pads made up of corrugated, single-faced flexible paper. Secure the cushioning with gummed paper tape. Wrap the cushioned

unit with corrugated, single-faced flexible paper and secure the wrap with gummed paper tape.

(2) *Spare indicator lamp and technical manuals.* Wrap the indicator lamp in corrugated, single-faced flexible paper and secure with gummed paper tape. Wrap the technical manuals in waterproof paper and seal the package with pressure-sensitive tape. Fasten the package containing the technical manuals to the top of the battery charger with pressure-sensitive tape. Fasten the spare indicator lamp package to the rear panel of the main unit with pressure-sensitive tape.

8-2. Packing

Pack the equipment as follows:

a. Use waterproof paper and pressure-sensitive tape to make a moisture-vaporproof barrier for the wooden packing case.

b. Place the consolidated package into the wooden packing case, cushion the top with corrugated, single-faced flexible paper, and seal the top of the moisture-vaporproof barrier with pressure-sensitive tape.

c. Nail the top to the wooden packing case.

Section II. DEMOLITION OF MATERIEL TO PREVENT ENEMY USE

8-3. Authority for Demolition

The demolition procedures given in paragraph 8-4 will be used to prevent the enemy from using or salvaging this equipment. Demolition of the equipment will be accomplished only upon the order of the commander.

8-4. Methods of Destruction

The tactical situation and time available will determine the method to be used when destruction

of equipment is ordered. In most cases, it is preferable to demolish completely some portions of the equipment rather than partially destroy all the equipment components.

a. Smash. Smash the cabinet, meters, and controls. Remove the top panel and smash the internal components.

b. Cut. Cut the wiring of the battery charger.

WARNING

Be extremely careful with explosives

and incendiary devices. Use these items only when the need is urgent.

c. Burn. Burn the technical manuals first. Burn as much of the equipment as is flammable.

d. Dispose. Bury or scatter destroyed parts or

throw them into nearby waterways. This is particularly important if the equipment has not been completely destroyed.

Figure 8-1. Color code markings for MIL-STD resistors, capacitors, and inductors.

(Located in back of manual)

APPENDIX A

REFERENCES

DA Pam 310-4	Index of Technical Manuals, Technical Bulletins, Supply Manuals (Types 7, 8, and 9), Supply Bulletins, and Lubrication Orders.
DA Pam 310-7	U.S. Army Index of Modification Work Orders.
SB 38-100	Preservation, Packaging, Packing and Marking Materials, Supplies, and Equipment Used by the Army.
TB 746-10	Field Instructions for Painting and Preserving Electronics Command Equipment.
TM 11-6625-203-12	Operator and Organizational Maintenance: Multimeter AN/URM-105, Including Multimeter ME-77/U.
TM 11-6625-320-12	Operator and Organizational Maintenance Manual: Voltmeter, Meter ME-30A/U and Voltmeters, Electronic ME-30B/U, ME-30C/U, and ME-30E/U.
TM 11-6625-366-15	Organizational, DS, GS, and Depot Maintenance Manual: Multimeter TS-352B/U.
TM 11-6625-444-15	Operator's, Organizational, DS, GS, and Depot Maintenance Manual: Digital Voltmeter AN/GSM-64.
TM 38-750	The Army Maintenance Management Systems (TAMMS).
TM 740-90-1	Administrative Storage of Equipment.

APPENDIX B

MAINTENANCE ALLOCATION

Section I. INTRODUCTION

B-1. General

This appendix provides a summary of the maintenance operations covered in the equipment literature for the PP-2309B/U. It authorizes categories of maintenance for specific maintenance functions on repairable items and components and the tools and equipment required to perform each function. This appendix may be used as an aid in planning maintenance operations.

B-2. Maintenance Functions

Maintenance functions will be limited to and defined as follows:

a. Inspect. To determine serviceability of an item by comparing its physical, mechanical, and electrical characteristics with established standards.

b. Test. To verify serviceability and to detect incipient electrical or mechanical failure by use of special equipment such as gages, meters, etc. This is accomplished with external test equipment and does not include operation of the equipment and operator type tests using internal meters or indicating devices.

c. Service. To clean, to preserve, to charge, and to add fuel, lubricants, cooling agents, and air. If it is desired that elements, such as painting and lubricating, be defined separately, they may be so listed.

d. Adjust. To rectify to the extent necessary to bring into proper operating range.

e. Align. To adjust two or more components or assemblies of an electrical or mechanical system so that their functions are properly synchronized. This does not include setting the frequency control knob of radio receivers or transmitters to the desired frequency.

f. Calibrate. To determine the corrections to be

made in the readings of instruments or test equipment used in precise measurement. Consists of the comparison of two instruments, one of which is a certified standard of known accuracy, to detect and adjust any discrepancy in the accuracy of the instrument being compared with the certified standard.

g. Install. To set up for use in an operational environment such as an encampment, site, or vehicle.

h. Replace. To replace unserviceable items with serviceable like items.

i. Repair. To restore an item to serviceable condition through correction of a specific failure or unserviceable condition. This function includes, but is not limited to welding, grinding, riveting, straightening, and replacement of parts other than the trial and error replacement of running spare type items such as fuses, lamps, or electron tubes.

j. Overhaul. Normally, the highest degree of maintenance performed by the Army in order to minimize time work in process is consistent with quality and economy of operation. It consists of that maintenance necessary to restore an item to completely serviceable condition as prescribed by maintenance standards in technical publications for each item of equipment. Overhaul normally does not return an item to like new, zero mileage, or zero hour condition.

k. Rebuild. The highest degree of material maintenance. It consists of restoring equipment as nearly as possible to new condition in accordance with original manufacturing standards. Rebuild is performed only when required by operational considerations or other paramount factors and then only at the depot maintenance category. Rebuild reduces to zero the hours or miles the equipment, or component thereof, has been in use.

l. Symbols. The uppercase letter placed in the

appropriate column indicates the lowest level at which that particular maintenance function is to be performed.

B-3. Explanation of Format

a. *Column 1, group number.* Not applicable.

b. *Column 2, functional group.* Column 2 lists the noun names of components, assemblies, sub-assemblies and modules on which maintenance is authorized.

c. *Column 3, maintenance functions.* Column 3 lists the maintenance category at which performance of the specific maintenance function is authorized. Authorization to perform a function at any category also includes authorization to perform that function at higher categories. The codes used represent the various maintenance categories as follows:

<i>Code</i>	<i>Maintenance Category</i>
C -----	Operator/crew
O -----	Organizational maintenance
F -----	Direct support maintenance
H -----	General support maintenance
D -----	Depot maintenance

d. *Column 4, tools and test equipment.* Column 4 specifies, by code, those tools and test equipment required to perform the designated

function. The numbers appearing in this column refer to specific tools and test equipment which are identified in table I.

e. *Column 5, Remarks.* Self-explanatory.

B-4. Explanation of Format of Table I, Tool and Test Equipment Requirements

The columns in Table I, Tool and Test Equipment Requirements are as follows:

a. *Tools and Equipment.* The numbers in this column coincide with the numbers used in the tools and equipment column of the Maintenance Allocation Chart. The numbers indicate the applicable tool for the maintenance function.

b. *Maintenance Category.* The codes in this column indicate the maintenance category normally allocated the facility.

c. *Nomenclature.* This column lists tools, test, and maintenance equipment required to perform the maintenance functions.

d. *Federal Stock Number.* This column lists the Federal stock number of the specific tool or test equipment.

e. *Tool Number.* Not used.

SECTION II. MAINTENANCE ALLOCATION CHART

MAINTENANCE ALLOCATION CHART																
GROUP NUMBER	FUNCTIONAL GROUP	MAINTENANCE FUNCTIONS										TOOLS AND EQUIPMENT	REMARKS			
		INSPECT	TEST	SERVICE	ADJUST	ALIGN	CALIBRATE	INSTALL	REPLACE	REPAIR	OVERHAUL			REBUILD		
	POWER SUPPLY PP-2309E/U	C		C	C				C							Visual Preventive maintenance Operational Replace running spares
		O	O	O												6 2,6 6 Input-output voltages Preventive maintenance
			F		F				F							3,4,5,9 3,4,5 Adjust voltages and links Faulty components
			H		H					F						5 1,3,4,7,8,9 Voltage regulation and ripple
										H						1,3,4,5,8,9 Voltage ranges
																6 All repairs
																1,3,4,5,7,8,9

TABLE I. TOOL AND TEST EQUIPMENT REQUIREMENTS

TOOL AND TEST EQUIPMENT REQUIREMENTS				
TOOLS AND EQUIPMENT	MAINTENANCE CATEGORY	NOMENCLATURE	FEDERAL STOCK NUMBER	TOOL NUMBER
		PP-2309B/U (continued)		
1	H,D	VOLTMETER, DIGITAL AN/GSM-64	6625-870-2264	
2	0	MULTIMETER AN/URM-105	6625-581-2036	
3	F,H,D	MULTIMETER TS-352B/U	6625-553-0142	
4	F,H,D	MULTIMETER, WESTON INSTRUMENTS MODEL 281	6625-356-8306	
5	F,H,D	TOOLKIT, ELECTRONIC EQUIPMENT TK-100/G	5180-605-0079	
6	0	TOOL KIT, ELECTRONIC EQUIPMENT TK-105/G	5180-610-8177	
7	H,D	TRANSFORMER, VARIABLE POWER TF-171A/U	5950-506-0632	
8	H,D	VOLTMETER, METER ME-30()/U	6625-643-1670	
9	F,H,D	RESISTOR, VARIABLE, WIREWOUND (0- to 7.5-OHM, 1,000-WATT)	5905-195-4496	

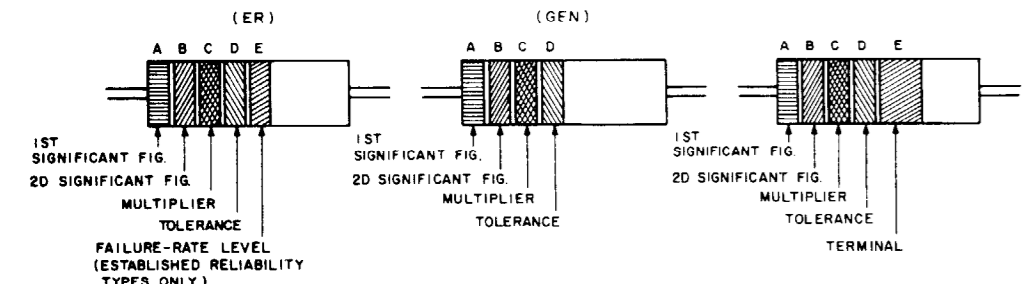

COLOR CODE MARKING FOR COMPOSITION TYPE RESISTORS. COLOR CODE MARKING FOR FILM-TYPE RESISTORS.

TABLE 1 COLOR CODE FOR COMPOSITION TYPE AND FILM TYPE RESISTORS.

BAND A		BAND B		BAND C		BAND D		BAND E	
COLOR	FIRST SIGNIFICANT FIGURE	COLOR	SECOND SIGNIFICANT FIGURE	COLOR	MULTIPLIER	COLOR	RESISTANCE TOLERANCE (PERCENT)	COLOR	FAILURE RATE LEVEL
BLACK	0	BROWN	1	BLACK	1	BROWN	M=1.0	BROWN	M=1.0
BROWN	1	BROWN	1	BROWN	10	RED	±1	RED	P=0.1
RED	2	RED	2	RED	100	ORANGE	±2	ORANGE	R=0.01
ORANGE	3	ORANGE	3	ORANGE	1,000	YELLOW	±5 (COMP. TYPE ONLY)	YELLOW	S=0.001
YELLOW	4	YELLOW	4	YELLOW	10,000	SILVER	±10 (COMP. TYPE ONLY)	WHITE	
GREEN	5	GREEN	5	GREEN	100,000	GOLD	±5		
BLUE	6	BLUE	6	BLUE	1,000,000	RED	±2 (NOT APPLICABLE TO ESTABLISHED RELIABILITY)		
PURPLE (VIOLET)	7	PURPLE (VIOLET)	7						
GRAY	8	GRAY	8	SILVER	1.01				
WHITE	9	WHITE	9	GOLD	0.1				

BAND A — THE FIRST SIGNIFICANT FIGURE OF THE RESISTANCE VALUE (BANDS A THRU D SHALL BE OF EQUAL WIDTH.)

BAND B — THE SECOND SIGNIFICANT FIGURE OF THE RESISTANCE VALUE.

BAND C — THE MULTIPLIER (THE MULTIPLIER IS THE FACTOR BY WHICH THE TWO SIGNIFICANT FIGURES ARE MULTIPLIED TO YIELD THE NOMINAL RESISTANCE VALUE.)

BAND D — THE RESISTANCE TOLERANCE.

BAND E — WHEN USED ON COMPOSITION RESISTORS, BAND E INDICATES ESTABLISHED RELIABILITY FAILURE-RATE LEVEL (PERCENT FAILURE PER 1,000 HOURS) ON FILM RESISTORS, THIS BAND SHALL BE APPROXIMATELY 1-1/2 TIMES THE WIDTH OF OTHER BANDS, AND INDICATES TYPE OF TERMINAL.

RESISTANCES IDENTIFIED BY NUMBERS AND LETTERS (THESE ARE NOT COLOR CODED)

SOME RESISTORS ARE IDENTIFIED BY THREE OR FOUR DIGIT ALPHA NUMERIC DESIGNATORS. THE LETTER R IS USED IN PLACE OF A DECIMAL POINT WHEN FRACTIONAL VALUES OF AN OHM ARE EXPRESSED. FOR EXAMPLE:

2R7 = 2.7 OHMS 10R0 = 10.0 OHMS

FOR WIRE-WOUND-TYPE RESISTORS COLOR CODING IS NOT USED, IDENTIFICATION MARKING IS SPECIFIED IN EACH OF THE APPLICABLE SPECIFICATIONS.

EXAMPLES OF COLOR CODING

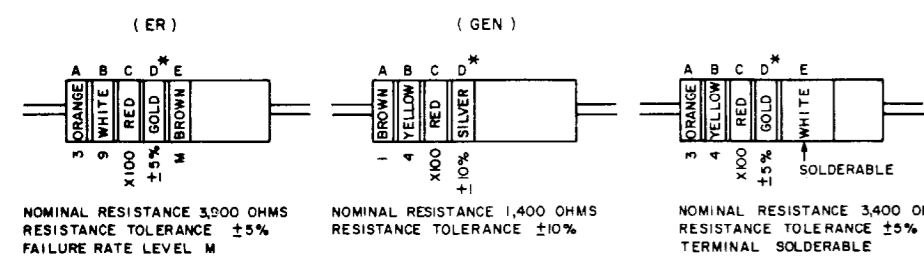

COMPOSITION-TYPE RESISTORS FILM-TYPE RESISTORS

* IF BAND D IS OMITTED, THE RESISTOR TOLERANCE IS ±20% AND THE RESISTOR IS NOT MIL-STD.

A. COLOR CODE MARKING FOR MILITARY STANDARD RESISTORS.

CAPACITORS, FIXED, VARIOUS-DIELECTRICS, STYLES CM, CN, CY, AND CB.

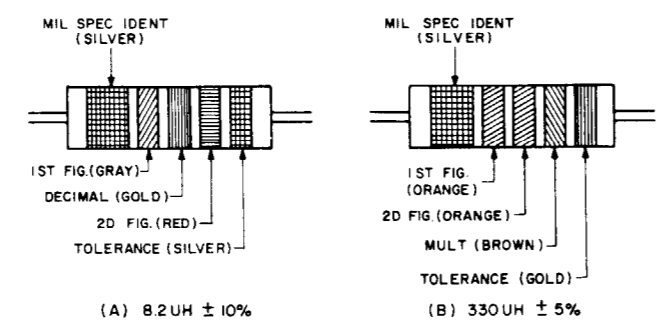
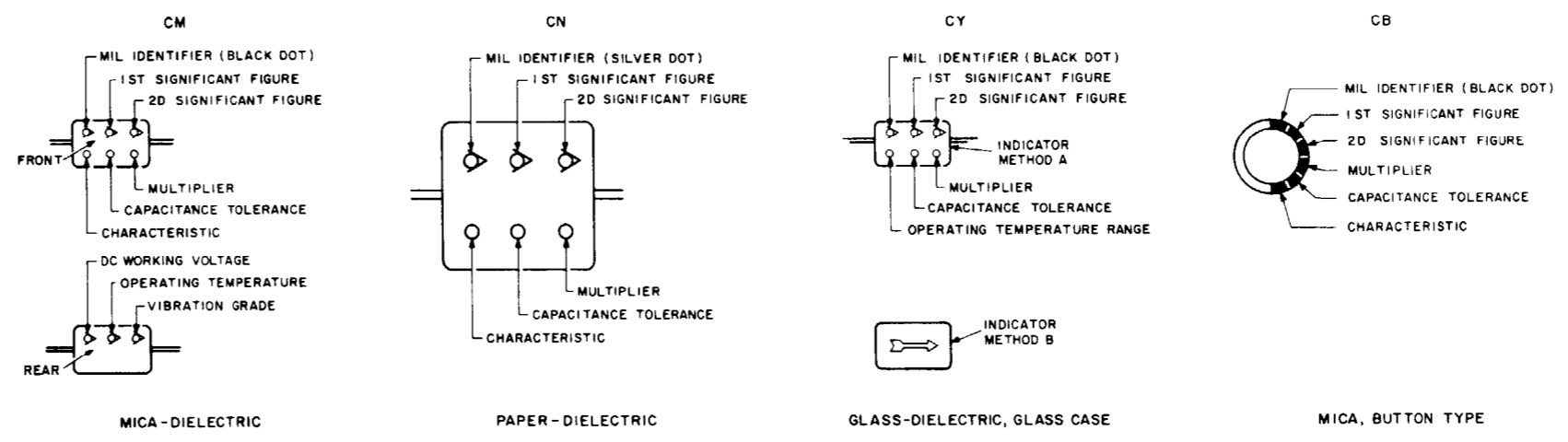

COLOR CODING FOR TUBULAR ENCAPSULATED R.F. CHOKES. AT A, AN EXAMPLE OF THE CODING FOR AN 8.2UH CHOKE IS GIVEN. AT B, THE COLOR BANDS FOR A 330UH INDUCTOR ARE ILLUSTRATED.

TABLE 2 COLOR CODING FOR TUBULAR ENCAPSULATED R.F. CHOKES.

COLOR	SIGNIFICANT FIGURE	MULTIPLIER	INDUCTANCE TOLERANCE (PERCENT)
BLACK	0	1	
BROWN	1	10	1
RED	2	100	2
ORANGE	3	1,000	3
YELLOW	4		
GREEN	5		
BLUE	6		
VIOLET	7		
GRAY	8		
WHITE	9		
NONE			20
SILVER			10
GOLD			5

MULTIPLIER IS THE FACTOR BY WHICH THE TWO COLOR FIGURES ARE MULTIPLIED TO OBTAIN THE INDUCTANCE VALUE OF THE CHOKE COIL.

B. COLOR CODE MARKING FOR MILITARY STANDARD INDUCTORS.

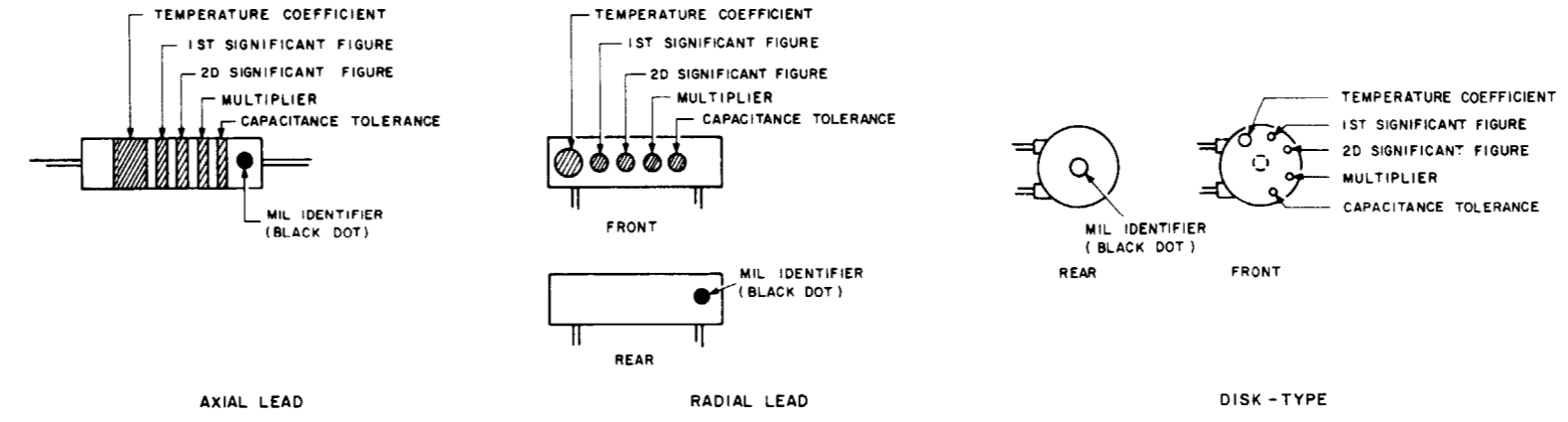

C. COLOR CODE MARKING FOR MILITARY STANDARD CAPACITORS

TABLE 3— FOR USE WITH STYLES CM, CN, CY AND CB.

COLOR	MIL ID	1ST SIG FIG	2D SIG FIG	MULTIPLIER	CAPACITANCE TOLERANCE				CHARACTERISTIC ²			DC WORKING VOLTAGE	OPERATING TEMP RANGE	VIBRATION GRADE
					CM	CN	CY	CB	CM	CN	CB			
BLACK	CM, CY, CB	0	0	1			±20%	±20%		A			-55* _{T0} +70°C	IO-55 HZ
BROWN		1	1	10						B	E	B		
RED		2	2	100	±2%		±2%	±2%		C			-55* _{T0} +85°C	
ORANGE		3	3	1,000		±30%				D		D	300	
YELLOW		4	4	10,000						E			-55* _{T0} +125°C	IO-2,000Hz
GREEN		5	5		±5%					F			500	
BLUE		6	6										-55* _{T0} +150°C	
PURPLE (VIOLET)		7	7											
GRAY		8	8											
WHITE		9	9											
GOLD				0.1			±5%	±5%						
SILVER	CN				±10%	±10%	±10%	±10%						

TABLE 4— TEMPERATURE COMPENSATING, STYLE CC.

COLOR	TEMPERATURE COEFFICIENT ⁴	1ST SIG FIG	2D SIG FIG	MULTIPLIER ¹	CAPACITANCE TOLERANCE		MIL ID
					CAPACITANCES OVER 10 UUF	CAPACITANCES 10 UUF OR LESS	
BLACK	0	0	0	1		±2.0 UUF	CC
BROWN	-30	1	1	10	±1%		
RED	-80	2	2	100	±2%	±0.25 UUF	
ORANGE	-150	3	3	1,000			
YELLOW	-220	4	4				
GREEN	-330	5	5		±5%	±0.5 UUF	
BLUE	-470	6	6				
PURPLE (VIOLET)	-750	7	7				
GRAY		8	8	0.01			
WHITE		9	9	0.1	±10%		
GOLD	+100					±1.0 UUF	
SILVER							

1. THE MULTIPLIER IS THE NUMBER BY WHICH THE TWO SIGNIFICANT (SIG) FIGURES ARE MULTIPLIED TO OBTAIN THE CAPACITANCE IN UUF.
2. LETTERS INDICATE THE CHARACTERISTICS DESIGNATED IN APPLICABLE SPECIFICATIONS: MIL-C-5, MIL-C-25D, MIL-C-11272B, AND MIL-C-10950C RESPECTIVELY.
3. LETTERS INDICATE THE TEMPERATURE RANGE AND VOLTAGE-TEMPERATURE LIMITS DESIGNATED IN MIL-C-11015D.
4. TEMPERATURE COEFFICIENT IN PARTS PER MILLION PER DEGREE CENTIGRADE.

Figure 8-1. Color code markings for MIL-STD resistors, capacitors, and inductors.

By Order of Secretary of the Army:

W. C. WESTMORELAND,
General, *United States Army*,
Chief of Staff.

Official:

VERNE L. BOWERS,
Major General, United States Army,
The Adjutant General.

Distribution:

Active Army

CNGB (1)
Dir of Trans (1)
COE (1)
TSG (1)
ACSC-E (2)
USAMB (10)
USAARENBD (2)
USASA (2)
USACDC (2)
USACDCCEA (1)
USACDCCEA
 Ft Huachuca (1)
CONARC (2)
AMC (1)
MICOM (2)
TECOM (2)
MUCOM (2)
ARADCOM (2)
ARADCOM Rgn (1)
ECOM (2)
OS Maj Comd (2)
USACDCEC (10)
USASTRATCOM (2)
USAESC (70)
Armies (1)
USASCS (20)
USASESS (10)
Svc Colleges (1)
Fort Huachuca (5)
WSMR (2)
Fort Carson (7)

USAERDAA (2)
USAERDAW (2)
USACRREL (2)
Army Dep (1) except
 LBAD (7)
 SAAD (30)
 TOAD (14)
 LEAD (7)
 ATAD (10)
 NAAD (3)
 SVAD (3)
USA Dep (1)
Sig Sec USA Dep (5)
Sig Dep (5)
Sig FLDMS (1)
Ft Richardson (ECOM Ofc) (2)
1st Cav Div (2)
Units org under fol TOE:
 (2 cys each unit)
 6-615
 6-616
 6-617
 6-619
 11-215
 1 1 - 5 0 0 (A A - A C)
 11-158
 29-134
 29-136
 29-500
 55-457
 55-458

NG: None.

USAR: None.

For explanation of abbreviations used, see AR 310-50.

RECOMMENDED CHANGES TO EQUIPMENT TECHNICAL PUBLICATIONS



THEN...JOT DOWN THE
DOPE ABOUT IT ON THIS FORM.
CAREFULLY TEAR IT OUT, FOLD IT
AND DROP IT IN THE MAIL.

SOMETHING WRONG WITH PUBLICATION

FROM: (PRINT YOUR UNIT'S COMPLETE ADDRESS)

DATE SENT

PUBLICATION NUMBER

PUBLICATION DATE

PUBLICATION TITLE

BE EXACT PIN-POINT WHERE IT IS

PAGE
NO.

PARA-
GRAPH

FIGURE
NO.

TABLE
NO.

IN THIS SPACE, TELL WHAT IS WRONG
AND WHAT SHOULD BE DONE ABOUT IT.

TEAR ALONG PERFORATED LINE

PRINTED NAME, GRADE OR TITLE AND TELEPHONE NUMBER

SIGN HERE

